



# INDICE 3/3

## SCHEDARIO TECNICO DELLE CHIUSURE DI SICUREZZA

### H INSTALLAZIONI

INSTALLAZIONE CONTROTELAIO STANDARD .....	H1	MONTAGGIO MANIGLIA-MANIGLIA .....	H27
INSTALLAZIONE CONTROTELAIO - INTERASSE CAVALLOTTI .....	H2	MONTAGGIO POMOLO CENTRALE .....	H28
INSTALLAZIONE CAVALLOTTO SU TESTATA CONTROTELAIO .....	H3	MONTAGGIO LAMIERINO DI RINFORZO SU BATT. CENT. PORTA DB ....	H29
INSTALLAZIONE CONTROTELAIO SUPER RIDOTTO .....	H4	MONTAGGIO CHIUDIORTA .....	H30
INSTALLAZIONE CONTROTELAIO - VERIFICHE .....	H5	SOSTITUZIONE BLOCCHETTO "MIA" PORTE DOPPIA MAPPA .....	H31
INSTALLAZIONE KIT IMBOTTE SU NUOVO CT .....	H6	MONTAGGIO GUARNIZIONE PERIMETRALE TELAIO .....	H32
MONTAGGIO TELAIO .....	H7	SMONTAGGIO CILINDRO DA CANTIERE .....	H33
MONTAGGIO BATTENTE .....	H8	MONTAGGIO CILINDRO ALTA SICUREZZA DEFINITIVO .....	H34
MONTAGGIO PORTA CON DIVERSE FINITURE CAR. STANDARD ....	H9	MONTAGGIO CILINDRO DI SERVIZIO DEFINITIVO Sentry 4 .....	H35
MONTAGGIO INTERNO CORRIDOIO .....	H10	MONTAGGIO CILINDRO DI SERVIZIO DEFINITIVO AT3 .....	H36
REGISTRAZIONE CERNIERE MICRON .....	H11	MONTAGGIO DEI COPRICERNIERA .....	H37
REGISTRAZIONE CERNIERE REGISTRABILI IN ALTEZZA .....	H12	INSTALLAZIONE TELAIO SENZA CONTROTELAIO .....	H38
REGISTRAZIONE LAMINA PARAFREDDO .....	H13	MONTAGGIO BATAACCHIO "ANELLO" .....	H39
REGISTRAZIONE REGISTRO ANTISCHEDA .....	H14	MONTAGGIO BATAACCHIO "TESTA DI LEONE" .....	H40
INSTALLAZIONE LIMITATORI D'APERTURA .....	H15	MONTAGGIO BATAACCHIO "ESAGONO" .....	H41
REGISTRAZIONE REGISTRO PORTE ELETTRA .....	H16	MONTAGGIO BATAACCHIO "BAROCCO" .....	H42
MONTAGGIO PERNO SU ANTA SEMIFISSA PORTE DB .....	H17	MONTAGGIO VETRO SU PORTE VITRA .....	H43
APERTURA ANTA SEMIFISSA PORTE DB .....	H18	MONTAGGIO PROFILO PARAPOLVERE SU BATTUTA CENTRALE .....	H44
MANUTENZIONE DEVIATORE E DISP. COMANDO ASTE .....	H19	INSTALLAZIONE PORTA FAST-SBLOCK .....	H45/H46
MANUTENZIONE PANNELLI DI RIVESTIMENTO IN ESSENZA .....	H20	INSTALLAZIONE PORTA SBLOCK-PUSH .....	H47/H48
MANUTENZIONE PANNELLI DI RIVESTIMENTO IN ALLUMINIO ....	H21	PRELIMINARI ALL'USO DELLA SERRATURA AD INGRANAGGI .....	H49
MANUTENZIONE PANNELLI DI RIVESTIMENTO IN ACCIAIO .....	H22	LAVORAZIONI SU TELAIO PER SBLOCCO ELETTRICO .....	H50
MONTAGGIO BATTUTA CENTRALE PORTE DB - ANTA MOBILE .....	H23	MONTAGGIO PORTA CON DIVERSE FINITURE e CAR. GRAFFA .....	H51
MONTAGGIO BATTUTA CENTRALE PORTE DB - ANTA SEMIFISSA ..	H24	MISURE TELAI E CONTROTELAI .....	H52
MONTAGGIO POMOLO FISSO .....	H25		
MONTAGGIO POMOLO GIREVOLE .....	H26		

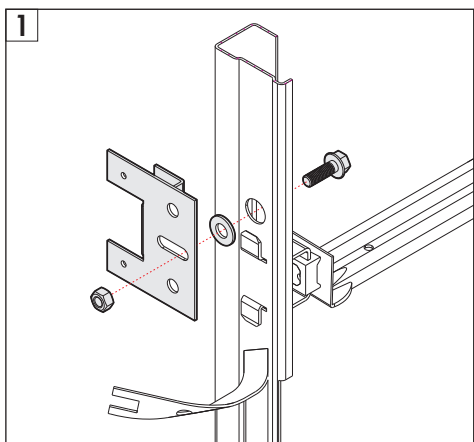
### J VARI-EXTRA

GUARNIZIONI SU PORTA 1 BATTENTE .....	J1	MONTAGGIO DOMINA 1A - 1L .....	J7
GUARNIZIONI SU PORTA TAGLIAFUOCO .....	J2	MONTAGGIO DOMINA 2A - 2L .....	J8
GUARNIZIONI SU PORTA + KIT ABB. ACUSTICO 38/42 Db .....	J3	CALCOLO DEL REGOLINO FERMAVETRO	
GUARNIZIONI SU PORTA DOPPIO BATTENTE .....	J4	PORTE SOPRALUCE E/O FIANCOLUCE .....	J9
GUARNIZIONI SU PORTA FINESTRATA .....	J5	DIMENSIONAMENTO VETRO	
DIMENSIONAMENTO VETRI SU PORTA FINESTRATA .....	J6	PORTE SOPRALUCE E/O FIANCOLUCE .....	J10

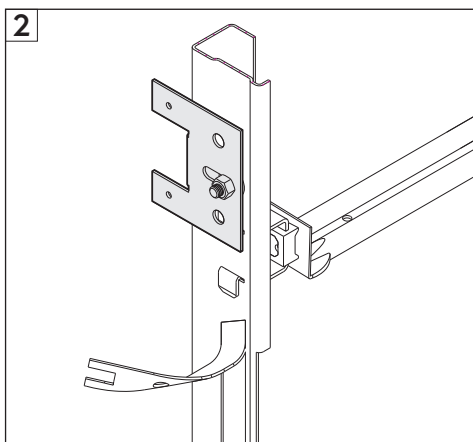
### K FALEGNAMERIA

FORATURA PORTE ELETTRA .....	K1-K16	DIMENSIONI ANTA SEMIFISSA .....	K159-K160
FORATURE PORTE D-CODE .....	K17-K44	SCANTONATURA-SBATTENTATURA PANNELLI SP. > 7 mm .....	K161-K163
FORATURA PORTE MECCANICHE .....	K45-K158	ESPLICATIVO RIVESTIMENTI .....	K164-K165

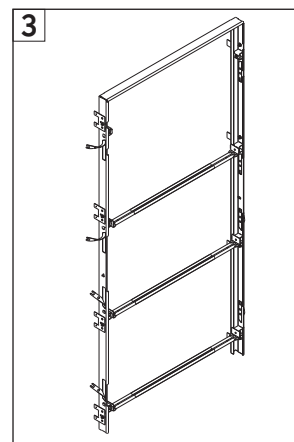
## Montaggio parti metalliche su Controtelaio



**Fig. 1** Montaggio delle 8 staffe metalliche (4 per lato): è necessario interporre la rondella tra staffa e controtelaio.

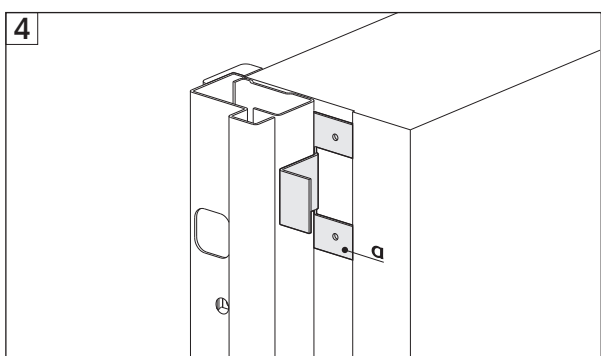


**Fig. 2** Particolare montato

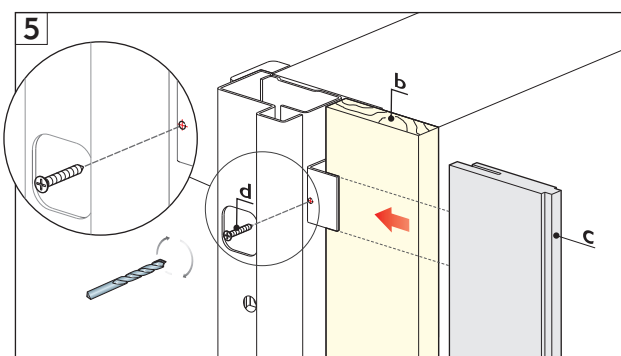


**Fig. 3** Controtelaio finito

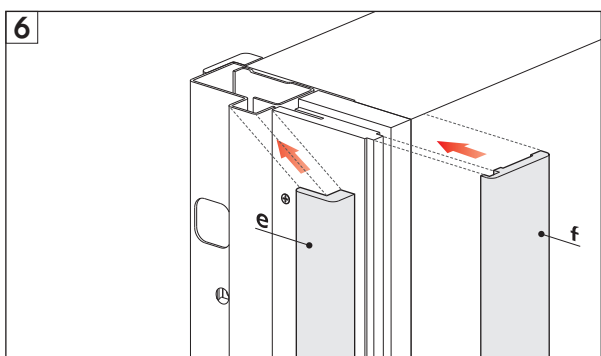
## Montaggio parti in legno



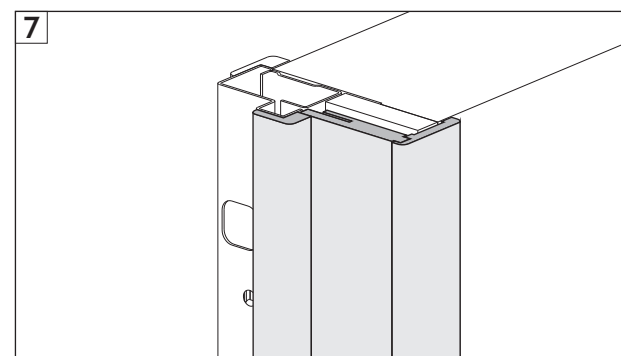
**Fig. 4** Il montaggio delle parti in legno parte da una situazione di controtelaio e telaio già montati e fissati. Il controtelaio deve essere predisposto per il kit imbotte, ovvero con le apposite **staffe (a)** già montate.



**Fig. 5** Montare il **supporto in legno (b)** delle dimensioni adeguate sulla parete. Incastrare l'elemento del kit imbotte dotato dell'apposita **fresata (c)** sulle staffe e fissare il tutto con viti autofilettanti **(d)**, dopo avere pre-forato con un trapano.



**Fig. 6** Montare l'angolare copritelaio **(e)** ed infine il coprifilo del kit imbotte **(f)** incastrandolo sull'elemento montato precedentemente **(c)**.



**Fig. 7** Kit imbotte montato.  
**N.B. è consigliabile usare collanti di tipo siliconico per il fissaggio degli elementi.**

I disegni sono esemplificativi e fuori scala.

Dierre si riserva il cambiamento della presente scheda senza preavviso  
**ESPRIMERE LE QUOTE IN MILLIMETRI**

## EXTRA PIÙ COMUNI

### POPULAR EXTRAS

#### EXTRA IN BASE ALLA TIPOLOGIA DI MURATURA

Installazione con zanche a murare (di serie)  
 Installazione con tasselli  
 Installazione con controtelaio  
 Installazione su mazzetta  
 Installazione su pareti  
 in cartongesso E<sub>l</sub> 60 e E<sub>l</sub> 120

#### EXTRA PER ESIGENZE DI SICUREZZA

Porte per uscite antipanico  
 Porte per uscite d'emergenza  
 Porte a 3 punti di chiusura  
 Porte normalmente aperte

#### EXTRA PER ESIGENZE D'IMPIEGO

Finestratura  
 Chiudiporta  
 Fascioni/zoccoli paracolpi  
 Imbotti  
 Porte con sopra luce e fiancoluci  
 Porte in acciaio inox

#### EXTRA PER CONTROLLO ACCESSI

Sblocco elettrico  
 Serrature elettriche  
 Elettromaniglia  
 Elettroblocco magnetico

#### EXTRA PER ESIGENZE ESTETICHE

Personalizzazione delle porte grazie  
 all'ampia gamma di finiture RAL

#### EXTRA PER ELEVATE ESIGENZE PRESTAZIONALI

Abbattimenti acustici  
 Tenuta aria/vento  
 Antieffrazione

#### EXTRAS BASED ON THE WALL TYPE

Installation with wall ties (standard)  
 Installation with bolts  
 Installation with subframe  
 Installation on reveal  
 Plasterboard wall installation  
 E<sub>l</sub> 60 and E<sub>l</sub> 120

#### EXTRAS FOR SAFETY REQUIREMENTS

Panic exit doors  
 Emergency exit doors  
 3-lock points doors  
 Normally open doors

#### EXTRAS FOR USAGE REQUIREMENTS

Grazing  
 Door closer  
 Bumper bands/skirting  
 Cornices  
 Doors with fanlights and side lights  
 Stainless steel doors

#### ACCESS CONTROL EXTRAS

Electric release  
 Electric locks  
 Electrohandle  
 Magnetic electric block

#### AESTHETIC EXTRAS

Door customisation thanks to the  
 wide range of RAL finishings

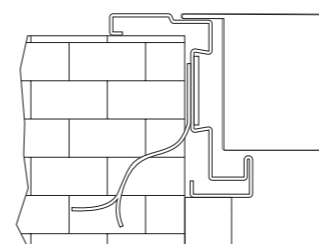
#### EXTRAS FOR HIGH-PERFORMANCE NEEDS

Noise reduction  
 Air/wind tightness  
 Burglar resistance

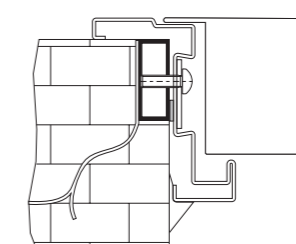
## SOLUZIONI DI FISSAGGIO

### FITTING SOLUTIONS

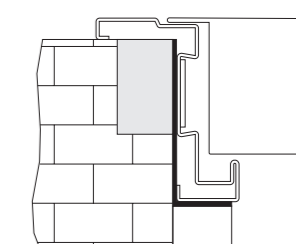
TELAIO A MURARE  
BRICK-IN FRAME



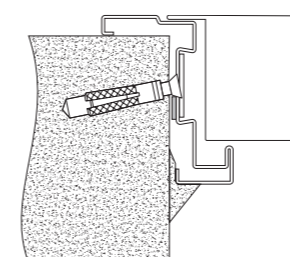
TELAIO SU CONTROTELAIO  
FRAME ON SUBFRAME



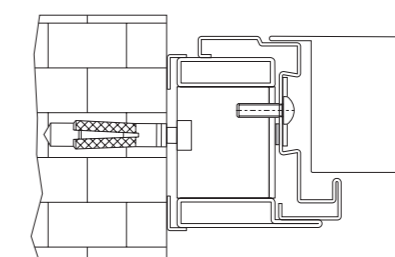
TELAIO SU CONTROTELAIO  
(solo PORTA FIREWALL)  
FRAME ON SUBFRAME  
(FIREWALL ONLY)



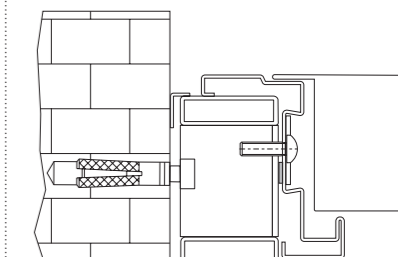
TELAIO A TASSELLARE  
BOLT-IN FRAME



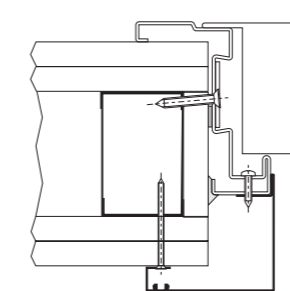
TELAIO SU MAZZETTA  
Tipo VISUAL CON PROFILO A "L"  
FRAME ON REVEAL  
VISUAL TYPE WITH "L" SHAPED PROFILE



TELAIO SU MAZZETTA  
Tipo VISUAL CON PROFILO A "T"  
FRAME ON REVEAL  
VISUAL TYPE WITH "T" SHAPED PROFILE

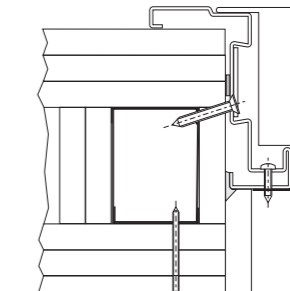


MONTAGGIO SU  
PARETE IN CARTONGESSO E<sub>l</sub> 60  
E<sub>l</sub> 60 PLASTERBOARD  
WALL MOUNT



L'imbotte non è necessario  
 con la marcatura CE  
 The padding is not necessary  
 with the CE marking


MONTAGGIO SU  
PARETE IN CARTONGESSO E<sub>l</sub> 120  
E<sub>l</sub> 120 PLASTERBOARD  
WALL MOUNT



L'imbotte non è necessario  
 con la marcatura CE  
 The padding is not necessary  
 with the CE marking

**CARATTERISTICHE PRESTAZIONALI STANDARD**  
STANDARD PERFORMANCE FEATURES

TRASMITTANZA TERMICA THERMAL TRANSMITTANCE		1,4 W/m²K
---	---	-----------

ABBATTIMENTO ACUSTICO NOISE REDUCTION		19 dB
--	---	-------

**DI SERIE STANDARD**

MANIGLIA + MANIGLIA CON SERRATURA ANTINCENDIO HANDLE + HANDLE WITH FIRE RESISTANT LOCK		
---	---	--

CERNIERE A VISTA EXPOSED HINGES		
------------------------------------	---	--

PESO WEIGHT		35 kg/m²
----------------	--	----------

**CARATTERISTICHE PRESTAZIONALI SUPPLEMENTARI**  
OPTIONAL PERFORMANCE FEATURES

KIT FUMI FREDDI (S <sub>0</sub> ) COLD FUMES KIT (S <sub>0</sub> )		SI / YES
KIT FUMI CALDI (S <sub>m</sub> /S <sub>200</sub> ) HOT FUMES KIT (S <sub>m</sub> /S <sub>200</sub> )		27 dB


ABBATTIMENTO ACUSTICO con soglia mobile NOISE REDUCTION with mobile threshold		27 dB
--	---	-------

ABBATTIMENTO ACUSTICO con soglia fissa (uscita NON CONFORME alle uscite d'emergenza) NOISE REDUCTION with fixed threshold (this exit is NOT COMPLIANT with emergency exit requirements)		34 dB
--	---	-------

PERMEABILITÀ ALL'ARIA E RESISTENZA AL CARICO DEL VENTO PERMEABILITY TO AIR AND RESISTANCE TO THE WIND LOAD		classe 4 C4
---	---	----------------

PORTA PER ESTERNI EN 14351-1 * Abbinare sempre almeno la guarnizione di battuta EXTERNAL DOOR EN 14351-1 * Always match at least the door stop seal		SI / YES
--	--	----------

**VARIANTI SUPPLEMENTARI**  
ADDITIONAL VARIATIONS

FINISTRATURA RETTANGOLARE/OBLÒ (vedi limiti a pagina 22) SQUARE WINDOW / ROUND WINDOW (see limits on page 22)		SI / YES
--	---	----------

SOPRALUCE/FIANCOLUCE FANLIGHT/SIDELIGHT		NO
--	---	----

ZOCCOLO/FASCIA PARACOLPI BUMPER SKIRTING/BAND		SI / YES
--	---	----------

CERNIERE A 3 ALI 3-FLAP HINGES		SI / YES
-----------------------------------	---	----------

MANIGLIERIA ANTIPANICO PANIC EXIT BAR		SI / YES
--	---	----------

SERRATURA A 3 PUNTI DI CHIUSURA 3 LOCK POINTS LOCK		SI / YES
---	---	----------

MANIGLIERIA CONFORME ALLE NORME DIN DIN COMPLIANT HANDLES		SI / YES
--	--	----------

**CONTROLLO ACCESSI**  
ACCESS MONITORING

SBLOCCO ELETTRICO ELECTRIC UNLOCK		SI / YES
--------------------------------------	--	----------

ELETTROMANIGLIA ELECTROHANDLE		SI / YES
----------------------------------	--	----------

SERRATURA ELETTRICA ELECTRIC LOCK		SI / YES
--------------------------------------	--	----------

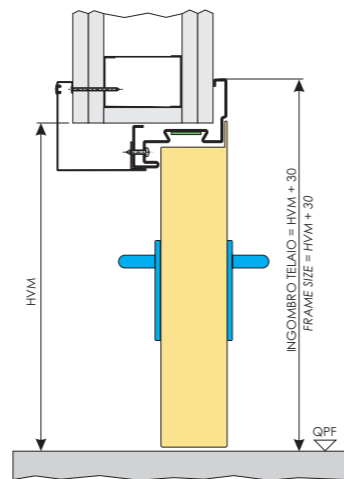
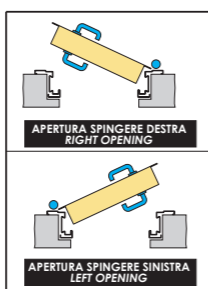
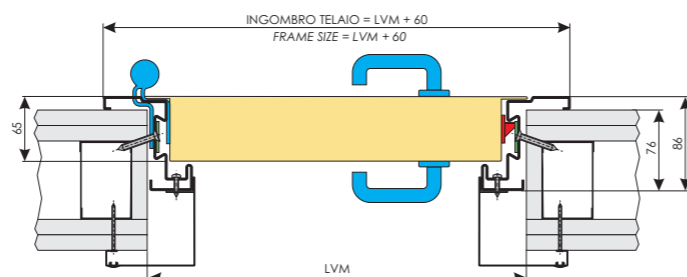
ELETTROMAGNETI ELECTROMAGNETS		SI / YES
----------------------------------	--	----------

ELETTROBLOCCHI MAGNETICI MAGNETIC ELECTRIC BLOCKS		SI / YES
--	--	----------

**DIMENSIONI CERTIFICATE**  
CERTIFIED DIMENSIONS (Per la disponibilità nella propria nazione, chiedere al ns ufficio tecnico)  
(Ask our technical assistance office for availability in your country)

LARGHEZZA (LVM) WIDTH (LVM)		675 ÷ 1350
--------------------------------	--	------------

ALTEZZA (HVM) HEIGHT (HVM)		1987 ÷ 2650
-------------------------------	--	-------------



I disegni sono esemplificativi e fuori scala  
Dierre si riserva il cambiamento della presente senza preavviso  
Le quote sono espresse in millimetri

Drawing are examples and not in scale  
Dierre holds the right to change this without notice  
Dimensions are expressed in millimetres

L'imbotte non è necessario con la marcatura CE  
The padding is not necessary with the CE marking

\* Per la compatibilità con i vari extra consultare il listino prezzi  
For compatibility with the various extras refer to the price list

**FINITURE**  
FINISHINGS

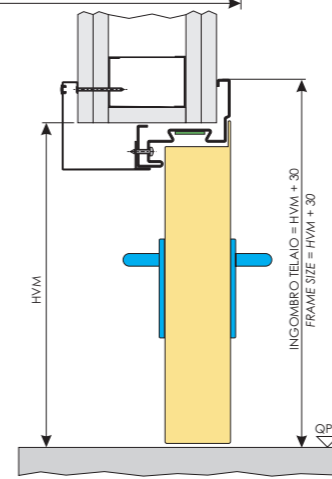
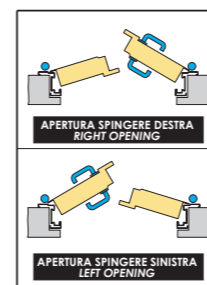
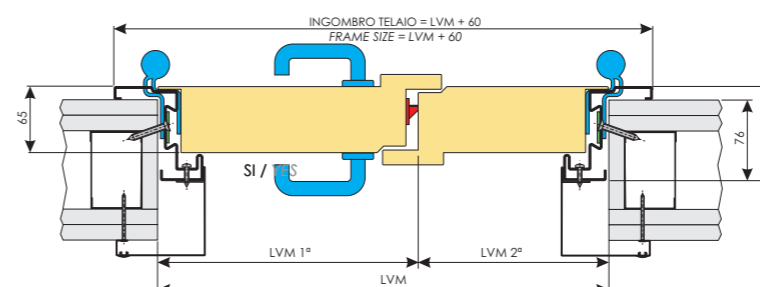
LACCATA RAL PER ESTERNI EXTERIOR RAL LACQUER		SI / YES
---	--	----------

IN ACCIAIO INOX STAINLESS STEEL		SI / YES
------------------------------------	--	----------

IN ACCIAIO PRERIVESTITO PRE-COATED STEEL		SI / YES
---	--	----------

**TIPOLOGIE DI MONTAGGIO**  
MOUNTING SOLUTIONS

SU PARETI IN CARTONGESSO  
ON PLASTERBOARD WALLS



I disegni sono esemplificativi e fuori scala  
Dierre si riserva il cambiamento della presente senza preavviso  
Le quote sono espresse in millimetri

Drawing are examples and not in scale  
Dierre holds the right to change this without notice  
Dimensions are expressed in millimetres

L'imbotte non è necessario con la marcatura CE  
The padding is not necessary with the CE marking

\* Per la compatibilità con i vari extra consultare il listino prezzi  
For compatibility with the various extras refer to the price list

**FINITURE**  
FINISHINGS

LACCATA RAL PER ESTERNI EXTERIOR RAL LACQUER		SI / YES
---	--	----------

IN ACCIAIO INOX STAINLESS STEEL		SI / YES
------------------------------------	--	----------

IN ACCIAIO PRERIVESTITO PRE-COATED STEEL		SI / YES
---	--	----------

**TIPOLOGIE DI MONTAGGIO**  
MOUNTING SOLUTIONS

SU PARETI IN CARTONGESSO  
ON PLASTERBOARD WALLS



**CARATTERISTICHE PRESTAZIONALI STANDARD**  
STANDARD PERFORMANCE FEATURES

TRASMITTANZA TERMICA THERMAL TRANSMITTANCE		1,7 W/m²K
---	---	-----------

ABBATTIMENTO ACUSTICO NOISE REDUCTION		19 dB
--	---	-------

**DI SERIE STANDARD**

MANIGLIA + MANIGLIA CON SERRATURA ANTINCENDIO HANDLE + HANDLE WITH FIRE RESISTANT LOCK		
---	---	--

CERNIERE A VISTA EXPOSED HINGES		
------------------------------------	---	--

PESO WEIGHT		35 kg/m²
----------------	--	----------


**CARATTERISTICHE PRESTAZIONALI SUPPLEMENTARI**  
OPTIONAL PERFORMANCE FEATURES

KIT FUMI FREDDI (S <sub>0</sub> ) COLD FUMES KIT (S <sub>0</sub> )		SI / YES
KIT FUMI CALDI (S <sub>m</sub> /S <sub>200</sub> ) HOT FUMES KIT (S <sub>m</sub> /S <sub>200</sub> )		25 dB


ABBATTIMENTO ACUSTICO con soglia mobile NOISE REDUCTION with mobile threshold		25 dB
--	---	-------

ABBATTIMENTO ACUSTICO con soglia fissa (uscita NON CONFORME alle uscite d'emergenza) NOISE REDUCTION with fixed threshold (this exit is NOT COMPLIANT with emergency exit requirements)		30 dB
--	---	-------

PERMEABILITÀ ALL'ARIA E RESISTENZA AL CARICO DEL VENTO PERMEABILITY TO AIR AND RESISTANCE TO THE WIND LOAD		classe 4 C4
---	---	----------------

PORTA PER ESTERNI EN 14351-1 * Abbinare sempre almeno la guarnizione di battuta EXTERNAL DOOR EN 14351-1 * Always match at least the door stop seal		SI / YES
--	--	----------

**VARIANTI SUPPLEMENTARI**  
ADDITIONAL VARIATIONS

FINISTRATURA RETTANGOLARE/OBLÒ (vedi limiti a pagina 22) SQUARE WINDOW / ROUND WINDOW (see limits on page 22)		SI / YES
--	---	----------

SOPRALUCE/FIANCOLUCE FANLIGHT/SIDELIGHT		NO
--	---	----

ZOCCOLO/FASCIA PARACOLPI BUMPER SKIRTING/BAND		SI / YES
--	---	----------

CERNIERE A 3 ALI 3-FLAP HINGES		SI / YES
-----------------------------------	---	----------

MANIGLIERIA ANTIPANICO PANIC EXIT BAR		SI / YES
--	---	----------

SERRATURA A 3 PUNTI DI CHIUSURA 3 LOCK POINTS LOCK		SI / YES
---	---	----------

MANIGLIERIA CONFORME ALLE NORME DIN DIN COMPLIANT HANDLES		SI / YES
--	--	----------

**CONTROLLO ACCESSI**  
ACCESS MONITORING

SBLOCCO ELETTRICO ELECTRIC UNLOCK		SI / YES
--------------------------------------	--	----------

ELETTROMANIGLIA ELECTROHANDLE		SI / YES
----------------------------------	--	----------

SERRATURA ELETTRICA ELECTRIC LOCK		SI / YES
--------------------------------------	--	----------

ELETTROMAGNETI ELECTROMAGNETS		SI / YES
----------------------------------	--	----------

ELETTROBLOCCHI MAGNETICI MAGNETIC ELECTRIC BLOCKS		SI / YES
--	--	----------

**DIMENSIONI CERTIFICATE**  
CERTIFIED DIMENSIONS (Per la disponibilità nella propria nazione, chiedere al ns ufficio tecnico)  
(Ask our technical assistance office for availability in your country)

LARGHEZZA (LVM) WIDTH (LVM)		1150 ÷ 2300 (575 + 575) ÷ (1150 + 1150)
--------------------------------	--	--

ALTEZZA (HVM) HEIGHT (HVM)		1987 ÷ 2650
-------------------------------	--	-------------

**CARATTERISTICHE PRESTAZIONALI STANDARD**  
STANDARD PERFORMANCE FEATURES

TRASMITTANZA TERMICA THERMAL TRANSMITTANCE		1,4 W/m²K
ABBATTIMENTO ACUSTICO NOISE REDUCTION		20 dB
<b>DI SERIE STANDARD</b>		
MANIGLIA + MANIGLIA CON SERRATURA ANTINCENDIO HANDLE + HANDLE WITH FIRE RESISTANT LOCK		
CERNIERE A VISTA EXPOSED HINGES		
PESO WEIGHT		40 kg/m²

**CARATTERISTICHE PRESTAZIONALI SUPPLEMENTARI**  
OPTIONAL PERFORMANCE FEATURES

KIT FUMI FREDDI (S <sub>0</sub> ) COLD FUMES KIT (S <sub>0</sub> )		SI / YES
KIT FUMI CALDI (S <sub>m</sub> /S <sub>200</sub> ) HOT FUMES KIT (S <sub>m</sub> /S <sub>200</sub> )		SI / YES
ABBATTIMENTO ACUSTICO con soglia mobile NOISE REDUCTION with mobile threshold		29 dB
ABBATTIMENTO ACUSTICO con soglia fissa (uscita NON CONFORME alle uscite d'emergenza) NOISE REDUCTION with fixed threshold (this exit is NOT COMPLIANT with emergency exit requirements)		35 dB
PERMEABILITÀ ALL'ARIA E RESISTENZA AL CARICO DEL VENTO PERMEABILITY TO AIR AND RESISTANCE TO THE WIND LOAD		classe 4 C4
PORTA PER ESTERNI EN 14351-1 * Abbinare sempre almeno la guarnizione di battuta EXTERNAL DOOR EN 14351-1 * Always match at least the door stop seal		SI / YES

**VARIANTI SUPPLEMENTARI**  
ADDITIONAL VARIATIONS

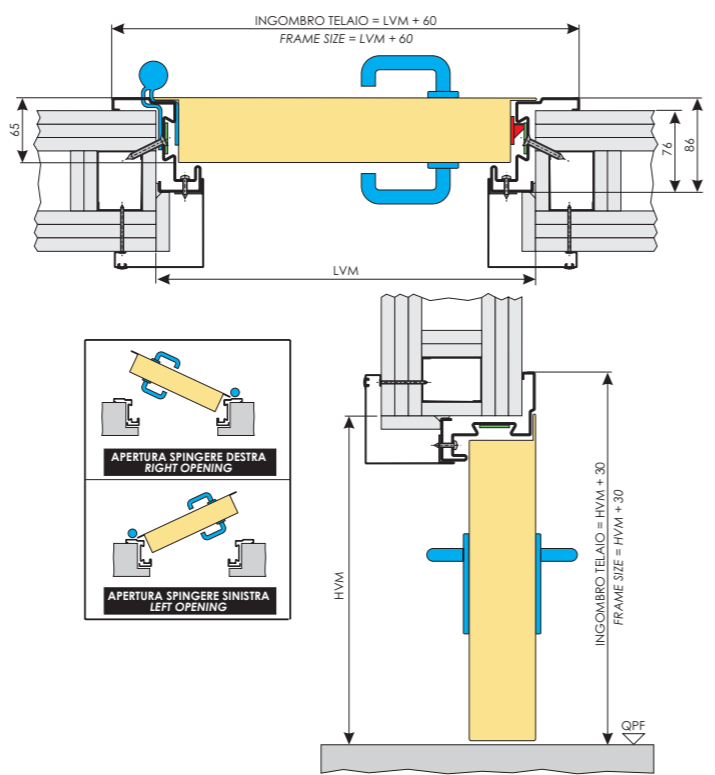
FINISTRATURA RETTANGOLARE/OBLÒ (vedi limiti a pagina 22) SQUARE WINDOW / ROUND WINDOW (see limits on page 22)		SI / YES
SOPRALUCE/FIANCOLUCE FANLIGHT/SIDELIGHT		NO
ZOCOLO/FASCIA PARACOLPI BUMPER SKIRTING/BAND		SI / YES
CERNIERE A 3 ALI 3-FLAP HINGES		SI / YES
MANIGLIERIA ANTIPANICO PANIC EXIT BAR		SI / YES
SERRATURA A 3 PUNTI DI CHIUSURA 3 LOCK POINTS LOCK		SI / YES
MANIGLIERIA CONFORME ALLE NORME DIN DIN COMPLIANT HANDLES		SI / YES

**CONTROLLO ACCESSI**  
ACCESS MONITORING

SBLOCCO ELETTRICO ELECTRIC UNLOCK	SI / YES
ELETTROMANIGLIA ELECTROHANDLE	SI / YES
SERRATURA ELETTRICA ELECTRIC LOCK	SI / YES
ELETTROMAGNETI ELECTROMAGNETS	SI / YES
ELETTROBLOCCHI MAGNETICI MAGNETIC ELECTRIC BLOCKS	SI / YES

**DIMENSIONI CERTIFICATE**  
CERTIFIED DIMENSIONS (Per la disponibilità nella propria nazione, chiedere al ns ufficio tecnico)  
(Ask our technical assistance office for availability in your country)

LARGHEZZA (LVM) WIDTH (LVM)	675 ÷ 1350
ALTEZZA (HVM) HEIGHT (HVM)	1987 ÷ 2650



I disegni sono esemplificativi e fuori scala. Dierre si riserva il cambiamento della presente senza preavviso. Le quote sono espresse in millimetri.

Drawing are examples and not in scale. Dierre holds the right to change this without notice. Dimensions are expressed in millimetres.


L'imbotte non è necessario con la marcatura CE. The padding is not necessary with the CE marking.

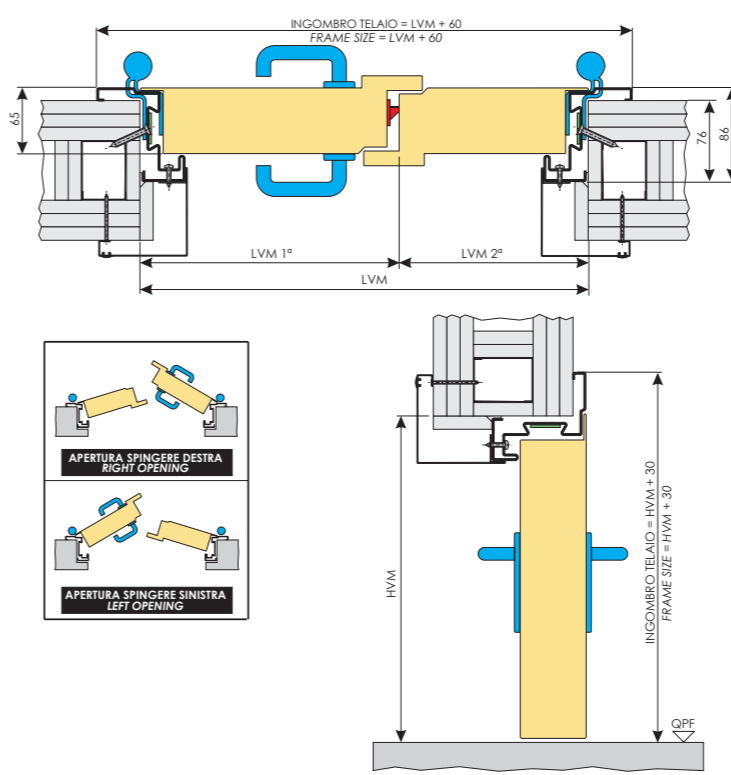
\* Per la compatibilità con i vari extra consultare il listino prezzi. For compatibility with the various extras refer to the price list.

**FINITURE**  
FINISHINGS

LACCATA RAL PER ESTERNI EXTERIOR RAL LACQUER	SI / YES
IN ACCIAIO INOX STAINLESS STEEL	SI / YES
IN ACCIAIO PRERIVESTITO PRE-COATED STEEL	SI / YES

**TIPOLOGIE DI MONTAGGIO**  
MOUNTING SOLUTIONS

SU PARETI IN CARTONGESSO ON PLASTERBOARD WALLS	
---	---



I disegni sono esemplificativi e fuori scala. Dierre si riserva il cambiamento della presente senza preavviso. Le quote sono espresse in millimetri.

Drawing are examples and not in scale. Dierre holds the right to change this without notice. Dimensions are expressed in millimetres.

L'imbotte non è necessario con la marcatura CE. The padding is not necessary with the CE marking.

\* Per la compatibilità con i vari extra consultare il listino prezzi. For compatibility with the various extras refer to the price list.

▫ Solo per porte certificate per esterni EN 14351-1. Only for EN 14351-1 certified exterior doors.

**FINITURE**  
FINISHINGS

LACCATA RAL PER ESTERNI EXTERIOR RAL LACQUER	SI / YES
IN ACCIAIO INOX STAINLESS STEEL	SI / YES ▫
IN ACCIAIO PRERIVESTITO PRE-COATED STEEL	SI / YES

**TIPOLOGIE DI MONTAGGIO**  
MOUNTING SOLUTIONS

SU PARETI IN CARTONGESSO ON PLASTERBOARD WALLS	
---	---

**CARATTERISTICHE PRESTAZIONALI STANDARD**  
STANDARD PERFORMANCE FEATURES

TRASMITTANZA TERMICA THERMAL TRANSMITTANCE		1,7 W/m²K
ABBATTIMENTO ACUSTICO NOISE REDUCTION		N.D.
<b>DI SERIE STANDARD</b>		
MANIGLIA + MANIGLIA CON SERRATURA ANTINCENDIO HANDLE + HANDLE WITH FIRE RESISTANT LOCK		
CERNIERE A VISTA EXPOSED HINGES		
PESO WEIGHT		40 kg/m²

**CARATTERISTICHE PRESTAZIONALI SUPPLEMENTARI**  
OPTIONAL PERFORMANCE FEATURES

KIT FUMI FREDDI (S <sub>0</sub> ) COLD FUMES KIT (S <sub>0</sub> )		SI / YES
KIT FUMI CALDI (S <sub>m</sub> /S <sub>200</sub> ) HOT FUMES KIT (S <sub>m</sub> /S <sub>200</sub> )		SI / YES
ABBATTIMENTO ACUSTICO con soglia mobile NOISE REDUCTION with mobile threshold		29 dB
ABBATTIMENTO ACUSTICO con soglia fissa (uscita NON CONFORME alle uscite d'emergenza) NOISE REDUCTION with fixed threshold (this exit is NOT COMPLIANT with emergency exit requirements)		35 dB
PERMEABILITÀ ALL'ARIA E RESISTENZA AL CARICO DEL VENTO PERMEABILITY TO AIR AND RESISTANCE TO THE WIND LOAD		classe 4 C4
PORTA PER ESTERNI EN 14351-1 * Abbinare sempre almeno la guarnizione di battuta EXTERNAL DOOR EN 14351-1 * Always match at least the door stop seal		SI / YES

**VARIANTI SUPPLEMENTARI**  
ADDITIONAL VARIATIONS

FINISTRATURA RETTANGOLARE/OBLÒ (vedi limiti a pagina 22) SQUARE WINDOW / ROUND WINDOW (see limits on page 22)		SI / YES
SOPRALUCE/FIANCOLUCE FANLIGHT/SIDELIGHT		NO
ZOCOLO/FASCIA PARACOLPI BUMPER SKIRTING/BAND		SI / YES
CERNIERE A 3 ALI 3-FLAP HINGES		SI / YES ▫
MANIGLIERIA ANTIPANICO PANIC EXIT BAR		SI / YES
SERRATURA A 3 PUNTI DI CHIUSURA 3 LOCK POINTS LOCK		SI / YES
MANIGLIERIA CONFORME ALLE NORME DIN DIN COMPLIANT HANDLES		SI / YES

**CONTROLLO ACCESSI**  
ACCESS MONITORING

SBLOCCO ELETTRICO ELECTRIC UNLOCK	SI / YES
ELETTROMANIGLIA ELECTROHANDLE	SI / YES
SERRATURA ELETTRICA ELECTRIC LOCK	SI / YES
ELETTROMAGNETI ELECTROMAGNETS	SI / YES
ELETTROBLOCCHI MAGNETICI MAGNETIC ELECTRIC BLOCKS	SI / YES

**DIMENSIONI CERTIFICATE**  
CERTIFIED DIMENSIONS (Per la disponibilità nella propria nazione, chiedere al ns ufficio tecnico)  
(Ask our technical assistance office for availability in your country)

LARGHEZZA (LVM) WIDTH (LVM)	1150 + 2300 (575 + 575) ÷ (1150 + 1150)
ALTEZZA (HVM) HEIGHT (HVM)	1987 + 2650