

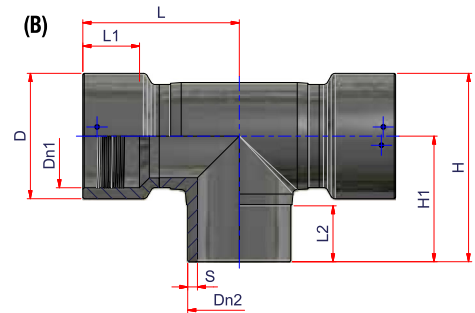

RACCORDI ELETTROSALDABILI ELECTROFUSION FITTINGS

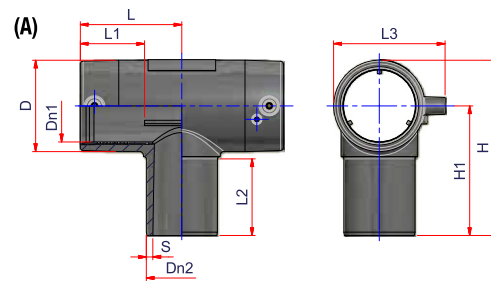

TEE ELETTROSALDABILE

(*) SDR max: saldabile su SDR 17,6 - 17 - 13,6 - 11 - 9 - 7,4

Tipo A monofilare con derivazione a codolo

Tipo B bifilare con derivazione a codolo

Tipo C bifilare

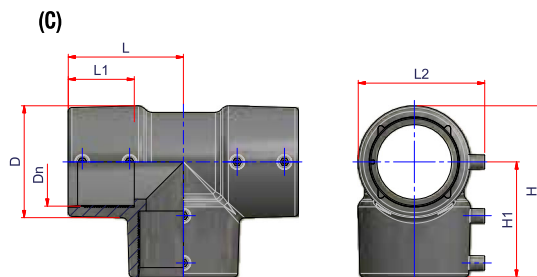

ELECTROFUSION EQUAL TEE

(*) SDR max: weldable on SDR 17,6 - 17 - 13,6 - 11 - 9 - 7,4

Type A single-wire with spigot end

Type B two-wire with spigot end

Type C two-wire

PE100 SDR11 PFA/PN16

Codice Code	Tipo Type	Ø	SDR max*	Imb. Pack.	Q.tà/Q.ty pallet	Peso Weight kg./p.	Volume m³/p.	Dn1	Dn2	S	D	L1	L2	L3	L	H1	H
12ETCE020	A	20	17,6	40	1.920	0,076	0,0004	20	20	3	32	37,5	46	52	45	66,5	83
12ETCE025	A	25	17,6	30	1.440	0,095	0,0006	25	25	3	37	37,5	46	57	50	68,5	87
12ETCE032	A	32	17,6	25	1.200	0,120	0,0007	32	32	3	44	37,5	47	64	55	75	96,5
12ETCE040	A	40	17,6	16	768	0,191	0,0011	40	40	3,7	54	44	54	74	66,5	84	111
12ETCE050	A	50	17,6	20	540	0,288	0,0018	50	50	4,6	65	46,5	61	85	76,5	100	133,5
12ETCE063	A	63	17,6	12	324	0,525	0,0003	63	63	5,8	80	57	68	99	90	115	156
12ETCE075	A	75	17,6	20	240	0,730	0,0040	75	75	6,8	95	58	72	112	98	130	178
12ETCE110	A	110	17,6	7	84	1,864	0,0114	110	110	10	139	83	88,5	156,5	144	177	247
12ETCE125	A	125	17,6	5	60	2,590	0,0160	125	125	11,4	158	88	94	174	157,5	191,5	270
12ETCE160	A	160	17,6	8	32	3,688	0,0270	160	160	14,6	190	87	105	201,5	151	208	303
12ETCE180	A	180	17,6	4	16	6,825	0,0540	180	180	16,4	210	92	105	230	165	245	350
12ETCE200	A	200	17,6	4	16	9,175	0,0540	200	200	18,2	235	115	115	250	195	245	375
12ETCE225	B	225	17,6	2	8	18,500	0,1080	225	225	20,5	274	124	125	-	342	275	412
12ETCE250	B	250	17,6	7	7	20,714	0,1289	250	250	22,7	308	120	135	-	377	305	459
12ETCE315	B	315	17,6	1	1	-	-	315	315	28,6	380	155	150	-	427	350	540

Codice Code	Tipo Type	Ø	SDR max*	Imb. Pack.	Q.tà/Q.ty pallet	Peso Weight kg./p.	Volume m³/p.	Dn	D	L1	L2	L	H1	H
12ETE090	C	90	17,6	10	120	1,390	0,0080	90	118	67,5	134	120	120	182